

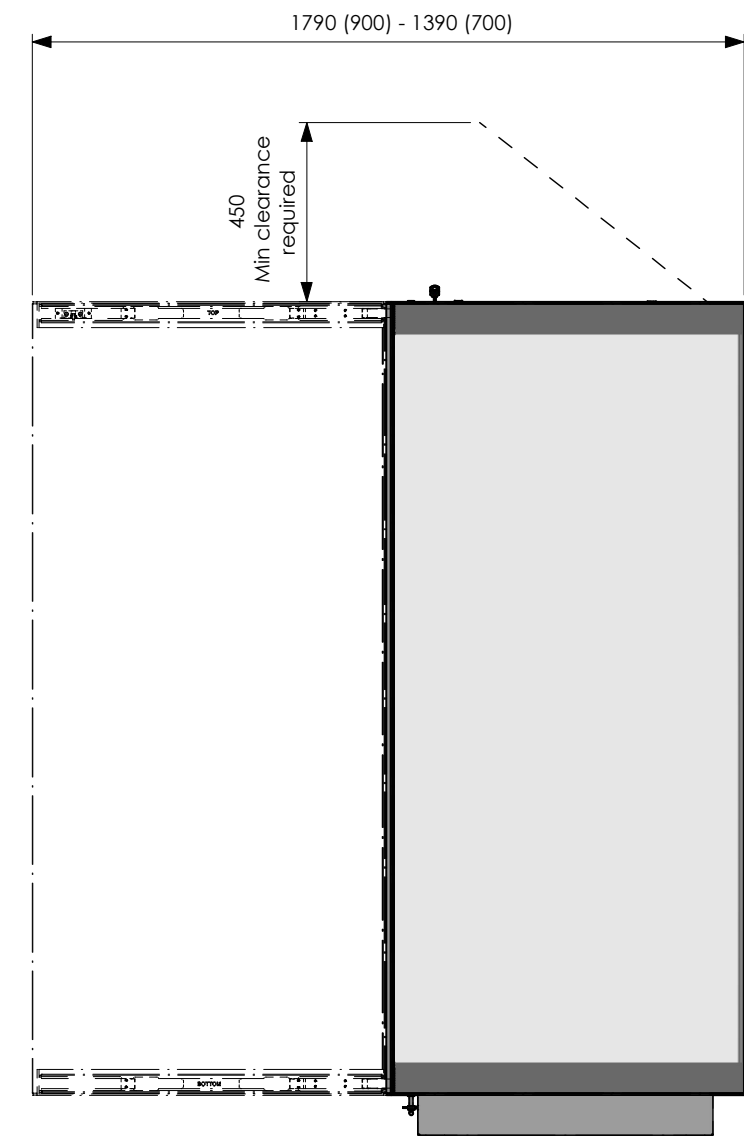

By Appointment to HM The Queen
Display Case Suppliers
Click Netherfield Limited

TESS EVOLUTION 2

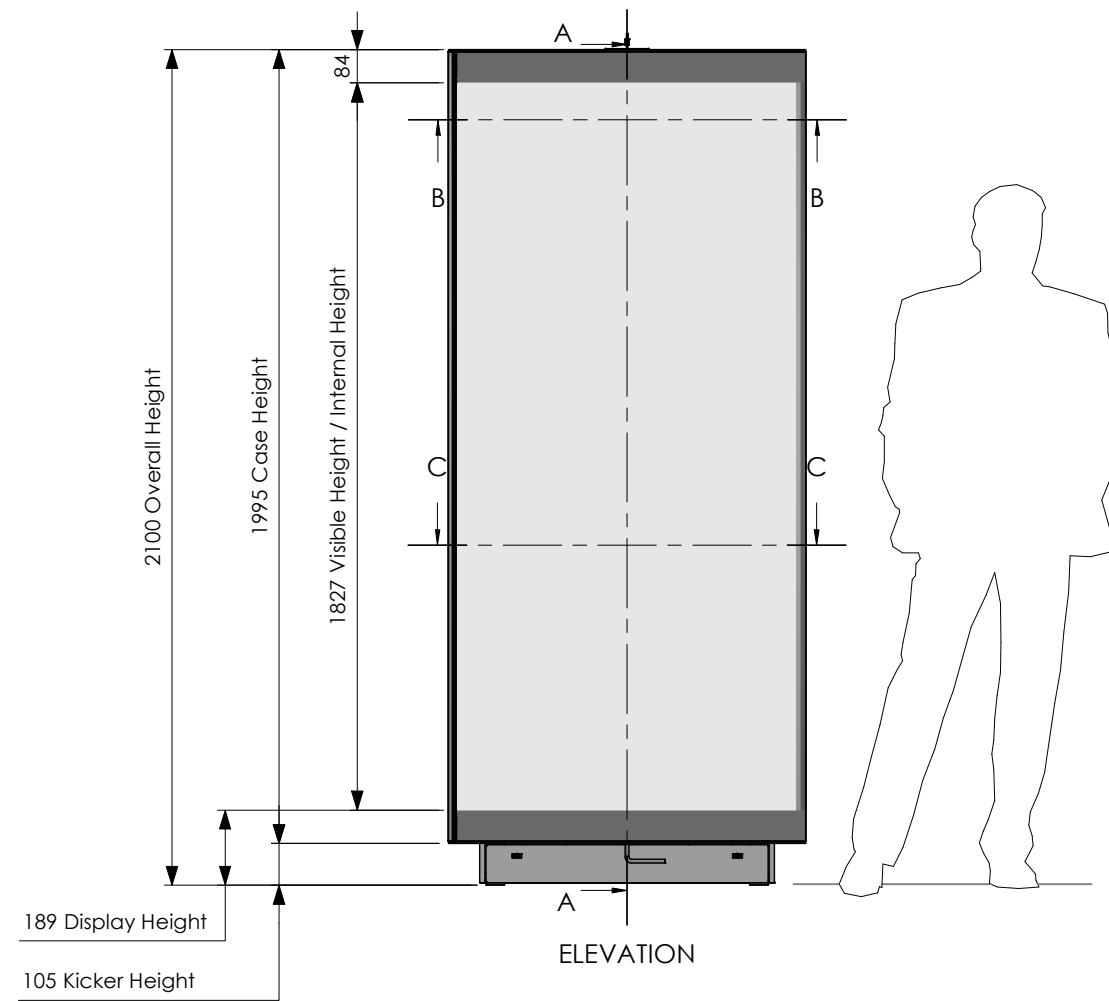
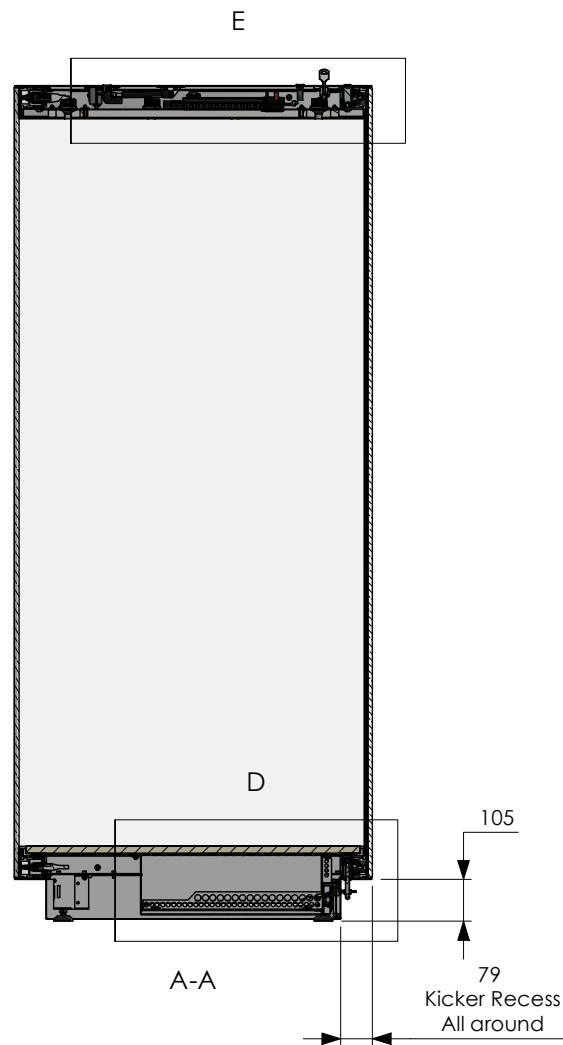
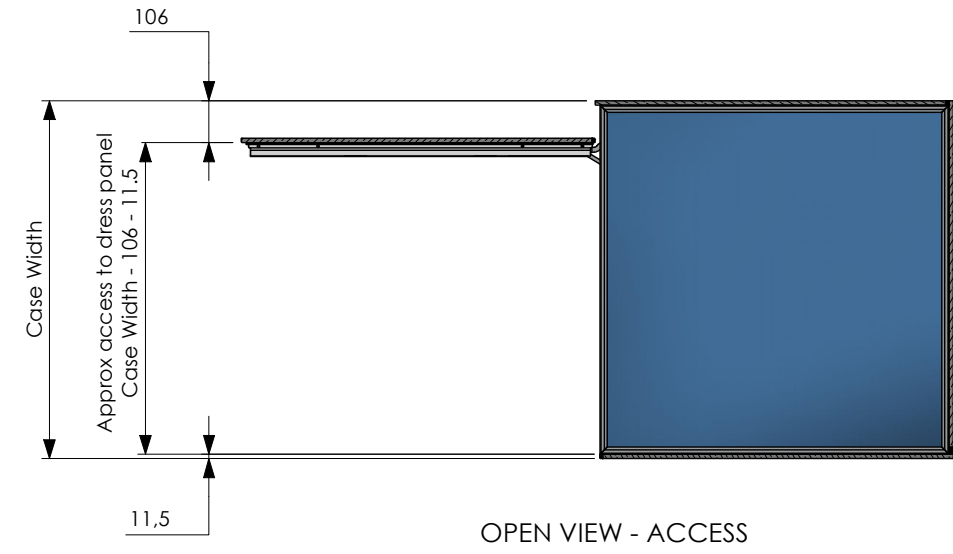
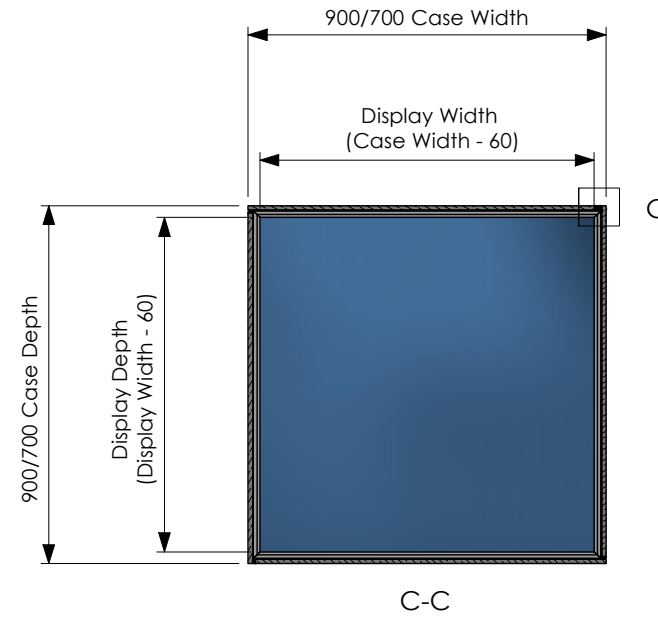
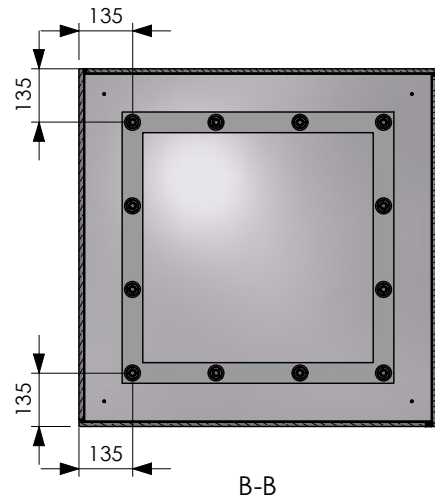

CLICKNETHERFIELD LTD
THE GLASSWORKS, GRANGE ROAD
HOUSTOUN INDUSTRIAL ESTATE
LIVINGSTON EH54 5DE, SCOTLAND
T +44 (0) 1506 835200
F +44 (0) 1506 835201
E SHOWCASES@CLICKNETHERFIELD.COM
WWW.CLICKNETHERFIELD.COM

REGISTERED IN SCOTLAND NO SC209017 VAT REG 848038508

CM00392-C-02.dwg Rev A



By Appointment to HM The Queen
Display Case Suppliers
Click Netherfield Limited

TESS EVOLUTION 2



IEC C14 socket on top
for power input from above

IEC Distribution block

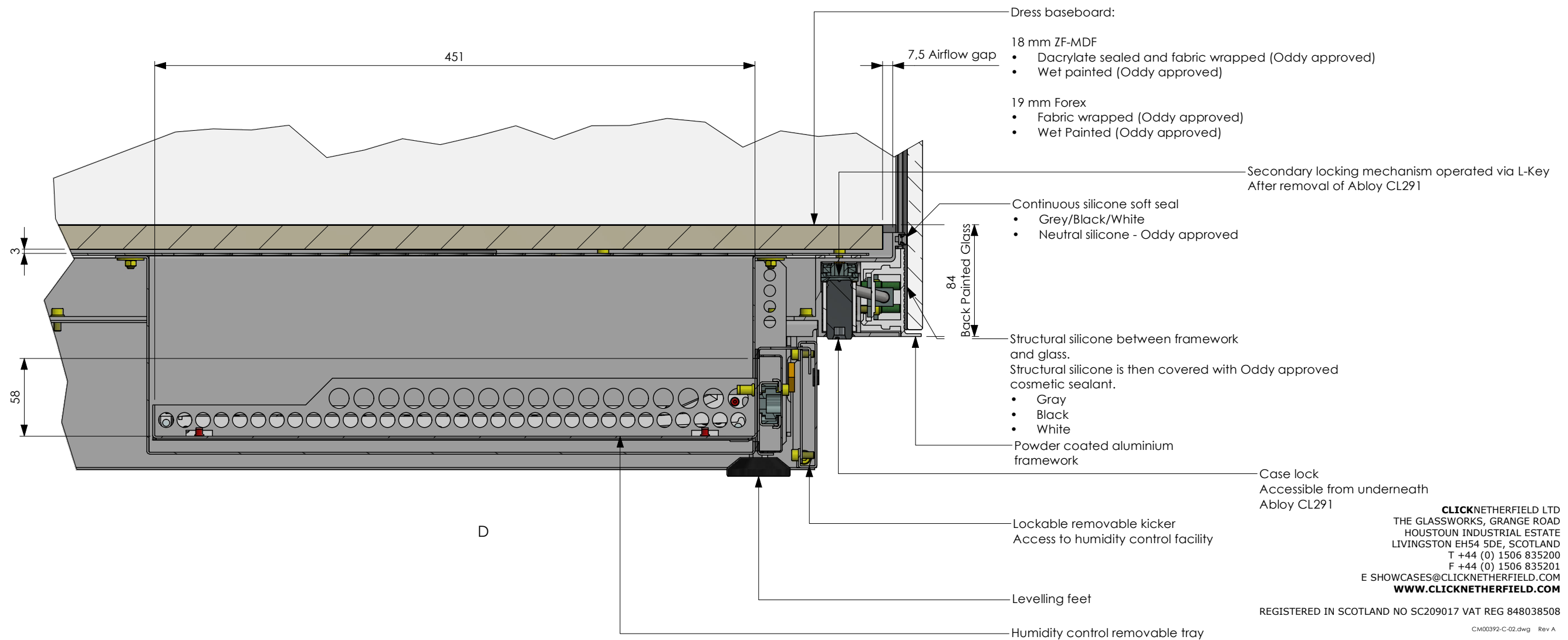
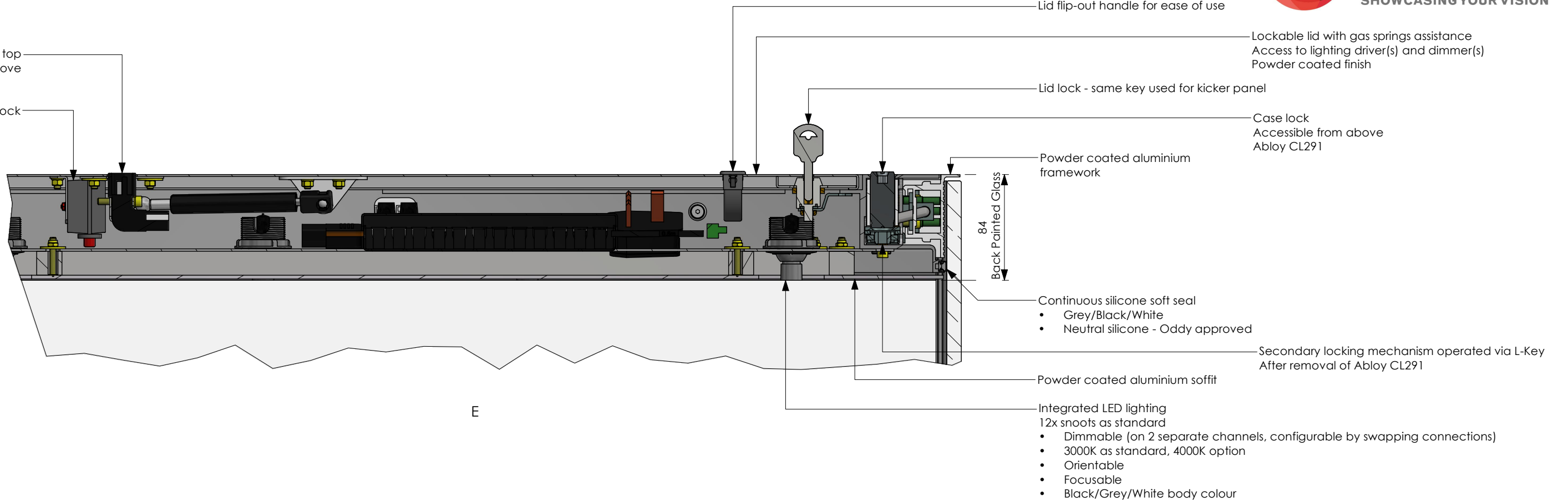

CLICKNETHERFIELD LTD
THE GLASSWORKS, GRANGE ROAD
HOUSTOUN INDUSTRIAL ESTATE
LIVINGSTON EH54 5DE, SCOTLAND
T +44 (0) 1506 835200
F +44 (0) 1506 835201
E SHOWCASES@CLICKNETHERFIELD.COM
WWW.CLICKNETHERFIELD.COM

REGISTERED IN SCOTLAND NO SC209017 VAT REG 848038508

CM00392-C-02.dwg Rev A



By Appointment to HM The Queen
Display Case Suppliers
Click Netherfield Limited

TESS EVOLUTION 2

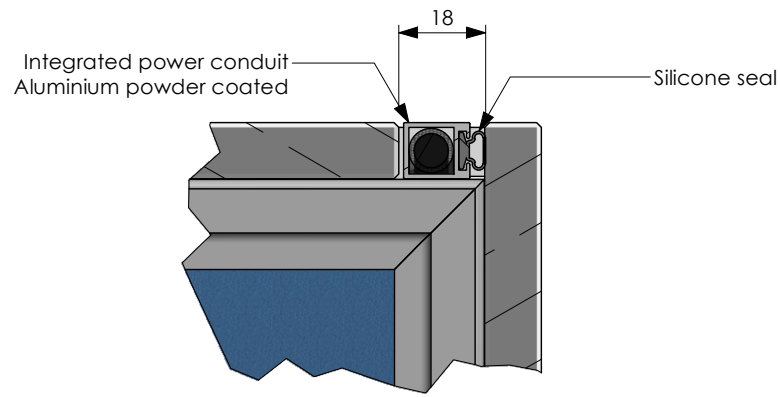

G
POWER CONDUIT DETAIL

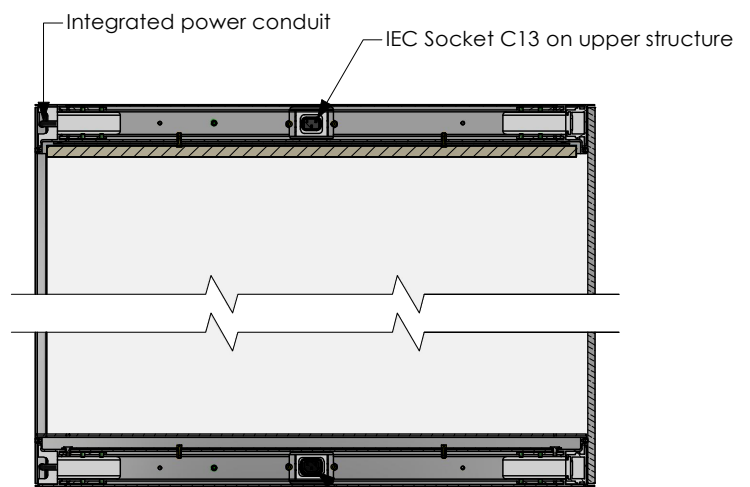

POWER TRANSFER BTM - TOP

Panel with power conduit
can be installed on left-back-right
side of showcase

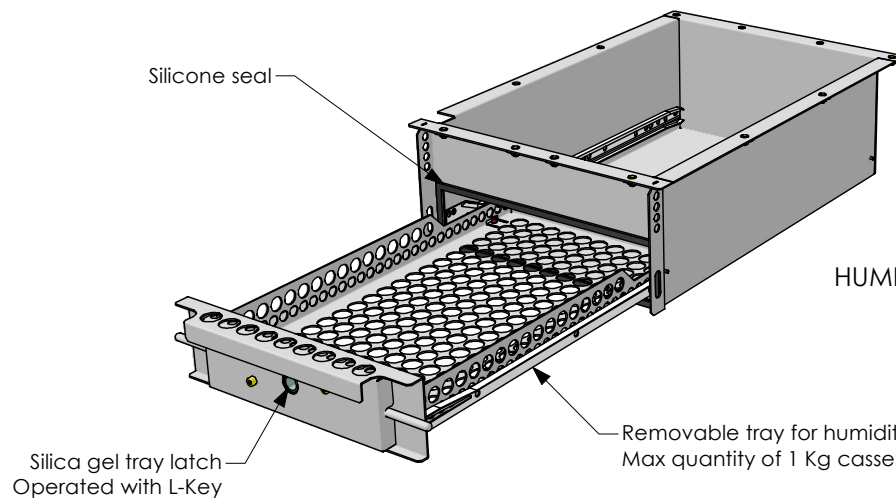

HUMIDITY CONTROL FACILITY

Door alignment wheel to ensure
perfect positioning of door

Heavy duty
CNC precision milled
maintenance free hinges

Lower locking mechanism

Heavy duty
CNC precision milled
maintenance free hinges

Upper locking mechanism



PERSPECTIVE (OPEN)

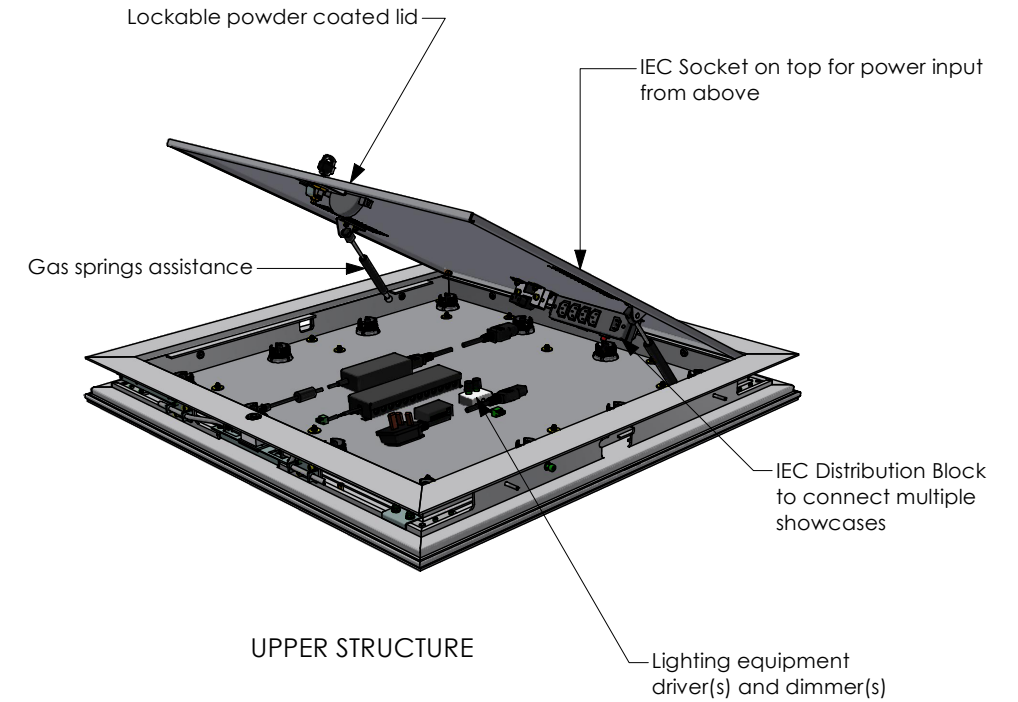

UPPER STRUCTURE

Sealing sheet with humidity control
box with tray
- Removable for accessing levelling feet

Perforation to prevent access to sealed
volume of showcase from large bodies

Recessed kicker allows showcase
to be moved with "Case Movers"

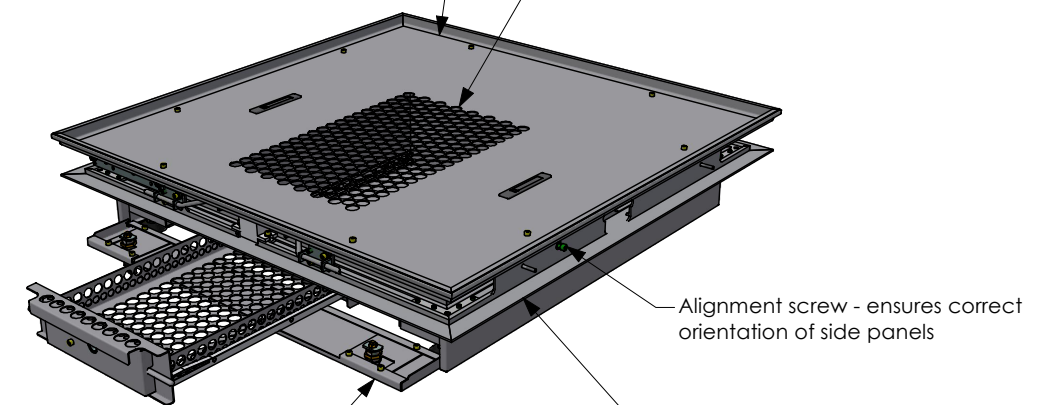

BOTTOM STRUCTURE

Lockable kicker to access
humidity control facility
Kicker can be easily removed for ease of access

CLICKNETHERFIELD LTD
THE GLASSWORKS, GRANGE ROAD
HOUSTON INDUSTRIAL ESTATE
LIVINGSTON EH54 5DE, SCOTLAND
T +44 (0) 1506 835200
F +44 (0) 1506 835201
E SHOWCASES@CLICKNETHERFIELD.COM
WWW.CLICKNETHERFIELD.COM

REGISTERED IN SCOTLAND NO SC209017 VAT REG 848038508

CM00392-C-02.dwg Rev A



By Appointment to HM The Queen
Display Case Suppliers
Click Netherfield Limited

TESS EVOLUTION 2



Height adjustable hanging rods shelving

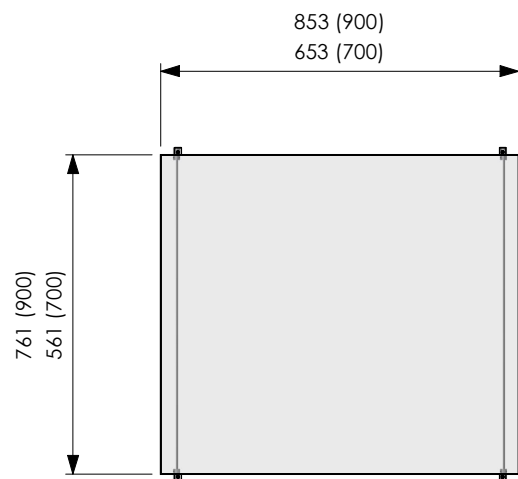
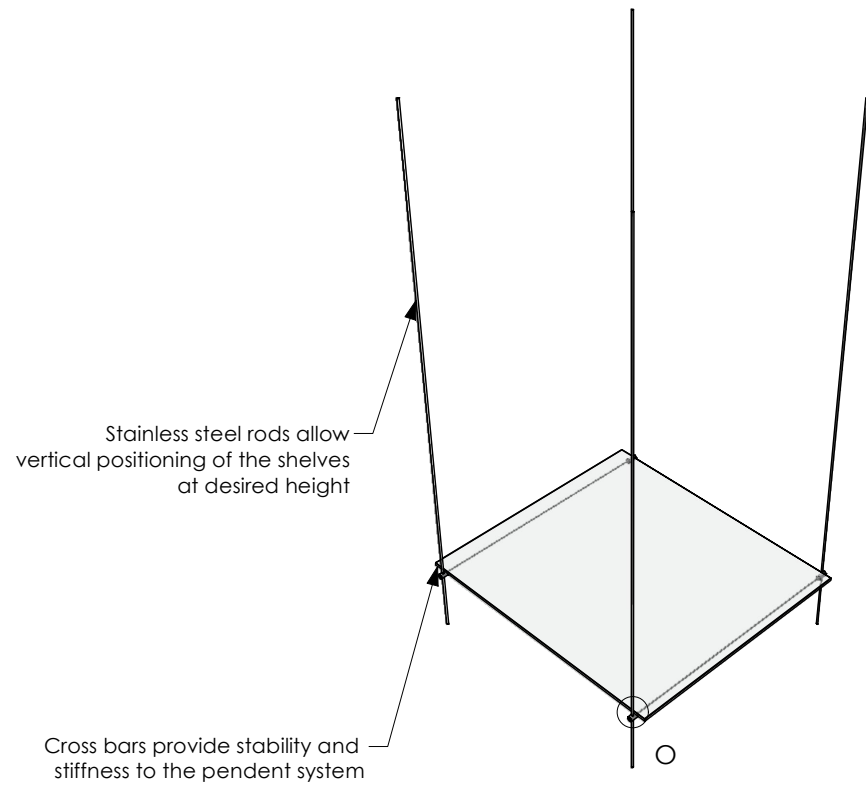

HANGING ROD SHELVING

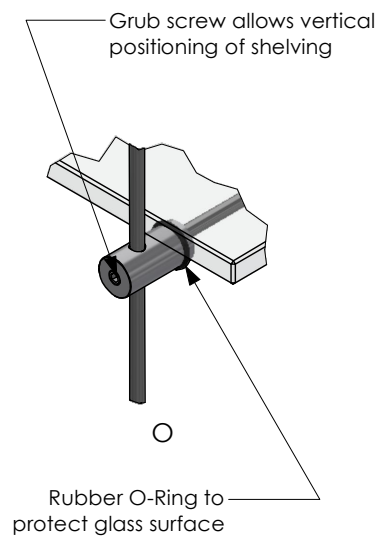

Glass top

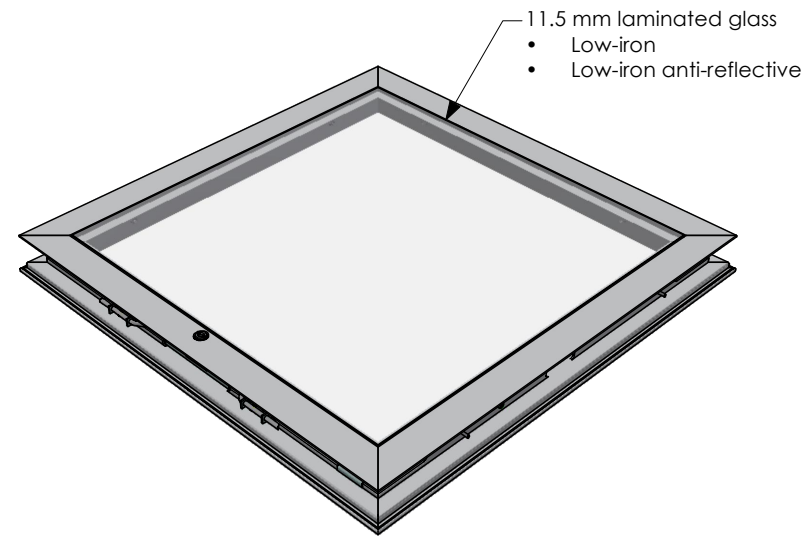

GLASS TOP
Interchangeable with solid top
Compatible with hanging rods shelving

Tray for humidity control cassettes

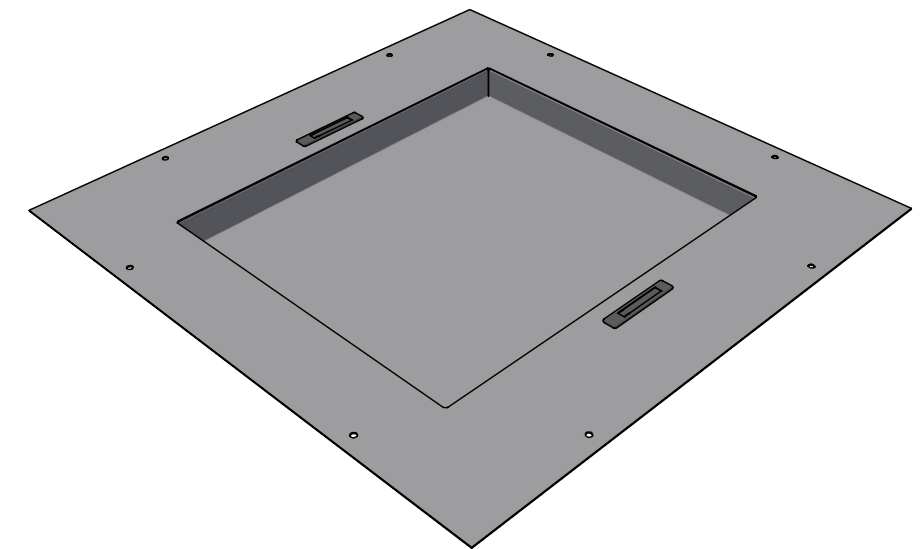
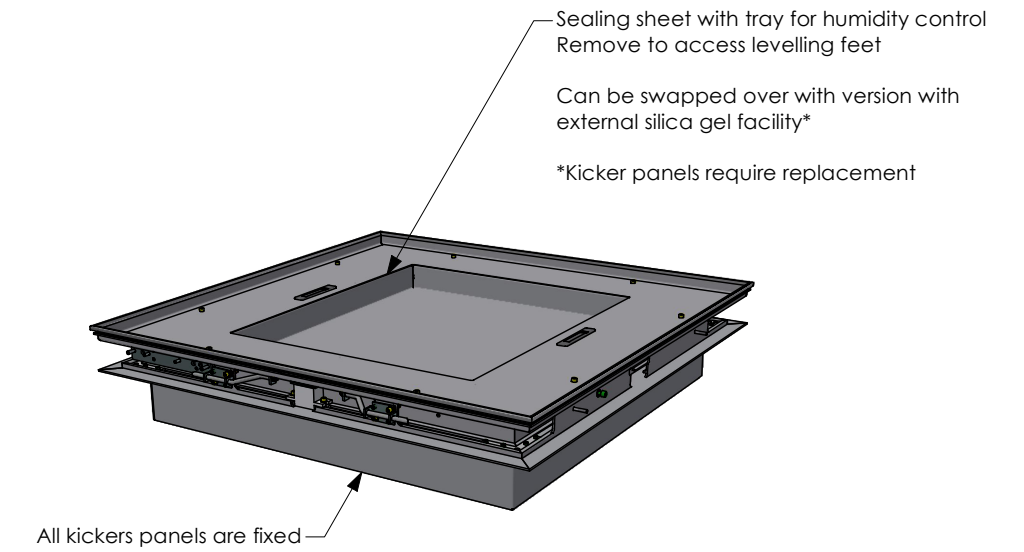

SEALING SHEET WITH HUMIDITY CONTROL TRAY
Up to 4x 1 Kg cassettes, accessible from underneath dress panel

MAXIMUM SHELF LOAD		
Shelf Qty	Max Weight per Shelf 900x900 [kg]	Max Weight per Shelf 700x700 [kg]
1	25	25
2	22.5	25
3	10	15
4	3.75	8.75
5	N/A	5

CLICKNETHERFIELD LTD
THE GLASSWORKS, GRANGE ROAD
HOUSTON INDUSTRIAL ESTATE
LIVINGSTON EH54 5DE, SCOTLAND
T +44 (0) 1506 835200
F +44 (0) 1506 835201
E SHOWCASES@CLICKNETHERFIELD.COM
WWW.CLICKNETHERFIELD.COM

REGISTERED IN SCOTLAND NO SC209017 VAT REG 848038508

CM00392-C-02.dwg Rev A



By Appointment to HM The Queen
Display Case Suppliers
Click Netherfield Limited

TESS EVOLUTION 2



- "Line abreast" configuration
- No limit in width
 - 1 upper and 1 lower joining rail required between two showcases
 - All doors hinged left to support top

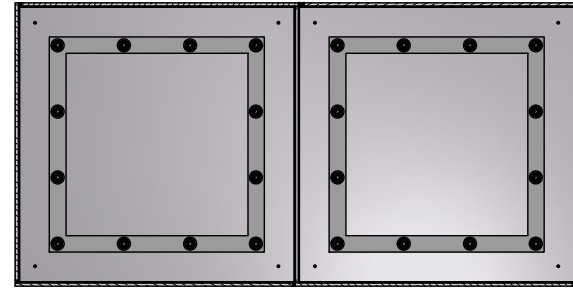

J-J

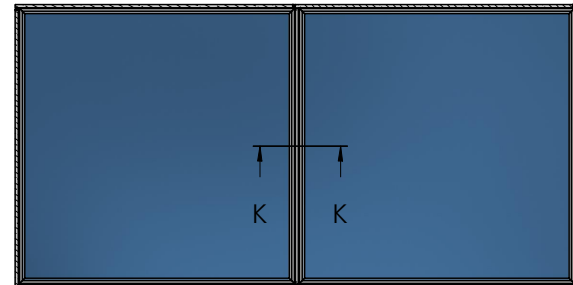

I-I

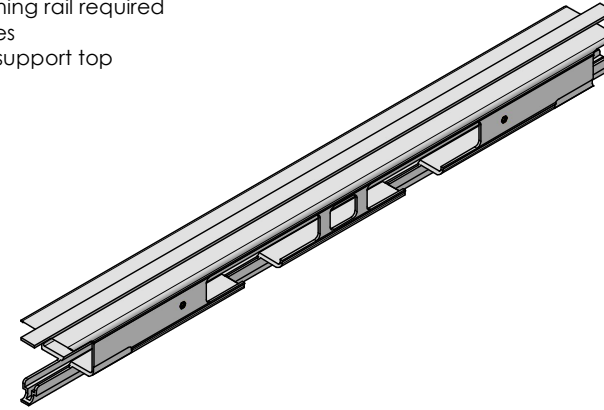
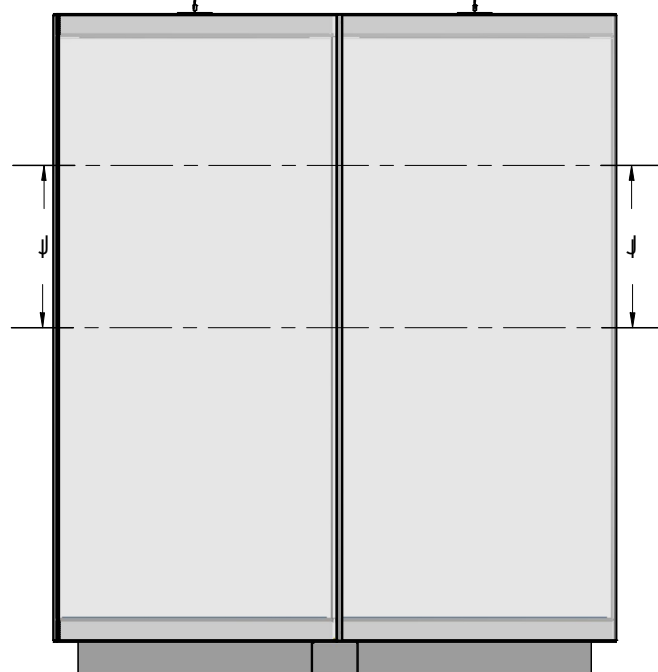
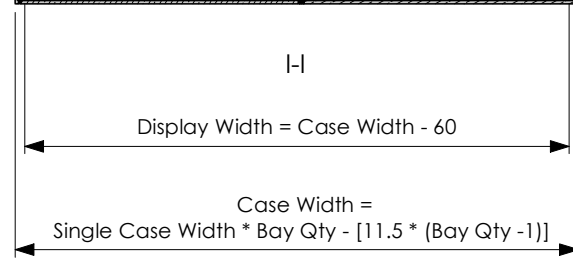

UPPER JOINING RAIL

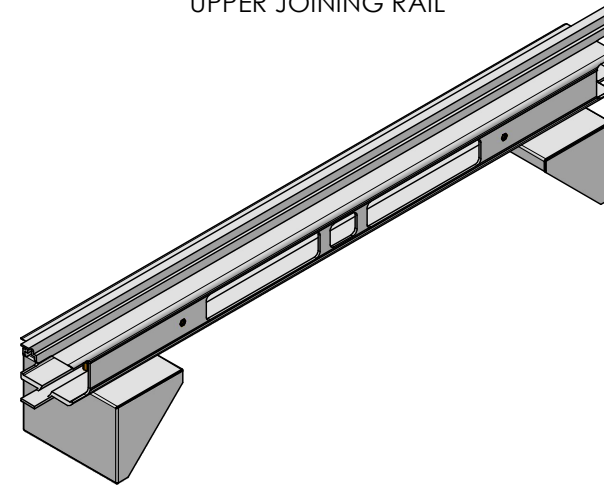

LOWER JOINING RAIL

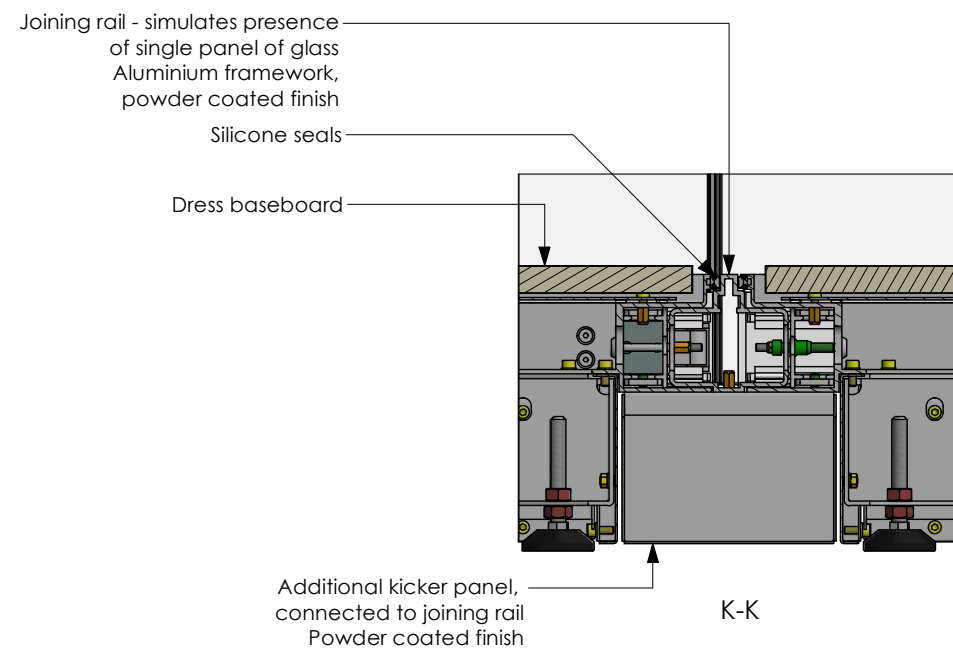
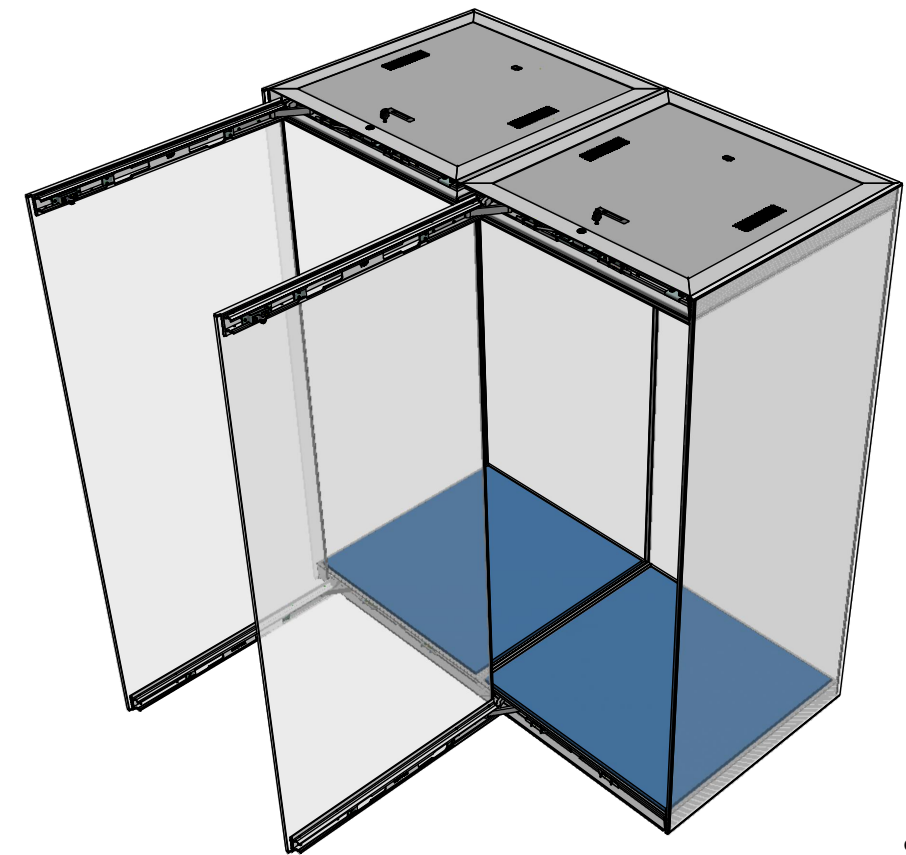
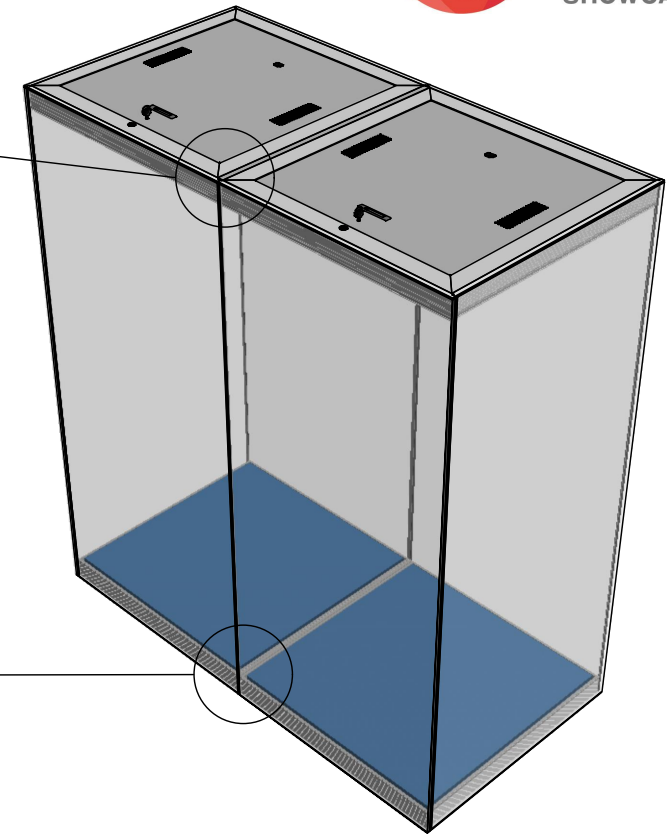

CLICKNETHERFIELD LTD
THE GLASSWORKS, GRANGE ROAD
HOUSTOUN INDUSTRIAL ESTATE
LIVINGSTON EH54 5DE, SCOTLAND
T +44 (0) 1506 835200
F +44 (0) 1506 835201
E SHOWCASES@CLICKNETHERFIELD.COM
WWW.CLICKNETHERFIELD.COM

REGISTERED IN SCOTLAND NO SC209017 VAT REG 848038508

CM00392-C-02.dwg Rev A



By Appointment to HM The Queen
Display Case Suppliers
Click Netherfield Limited

TESS EVOLUTION 2

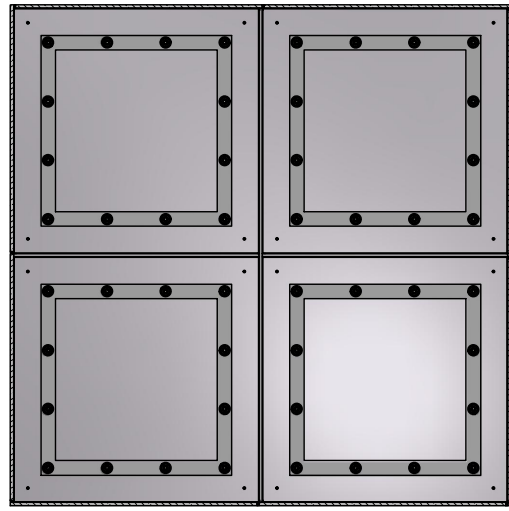

N-N

- "Box" configuration
- No limit in width
 - Double/Triple/Quadruple joining rail across one direction to support top structure - Max length 4 bays
 - Single joining rails across the other direction
 - All doors hinged left to support top

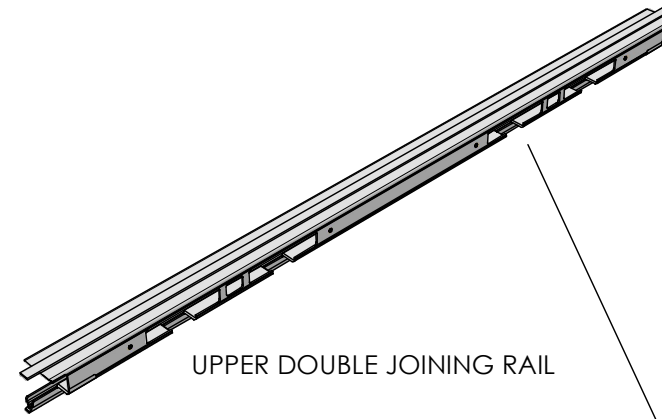
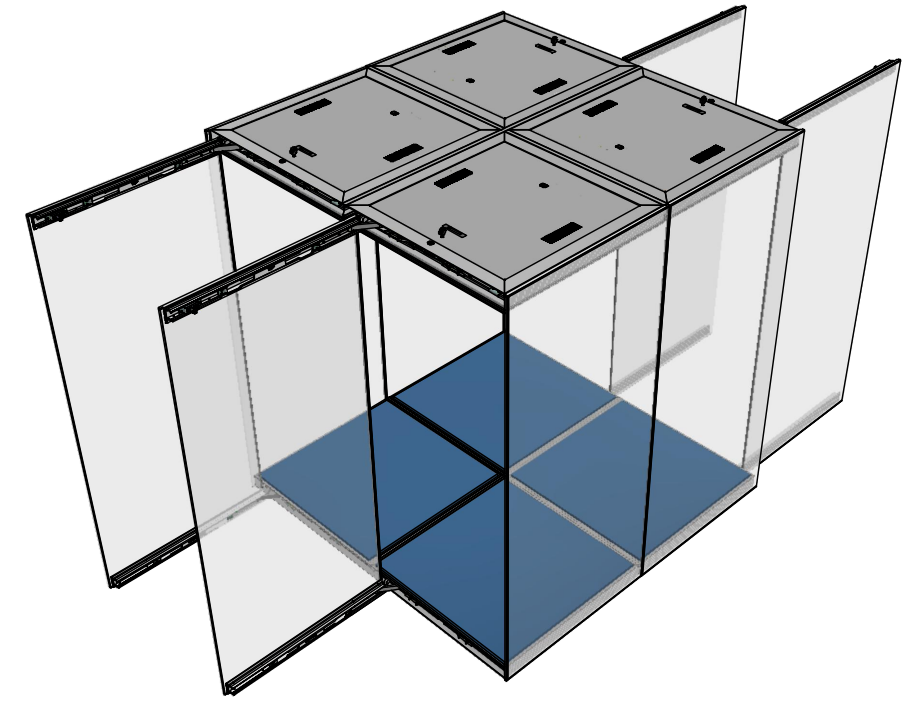

UPPER DOUBLE JOINING RAIL

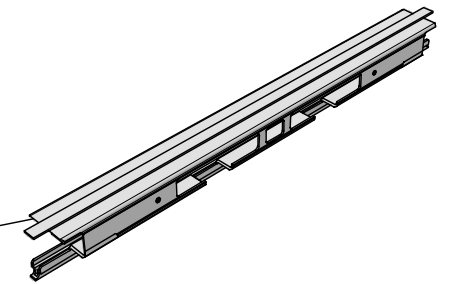
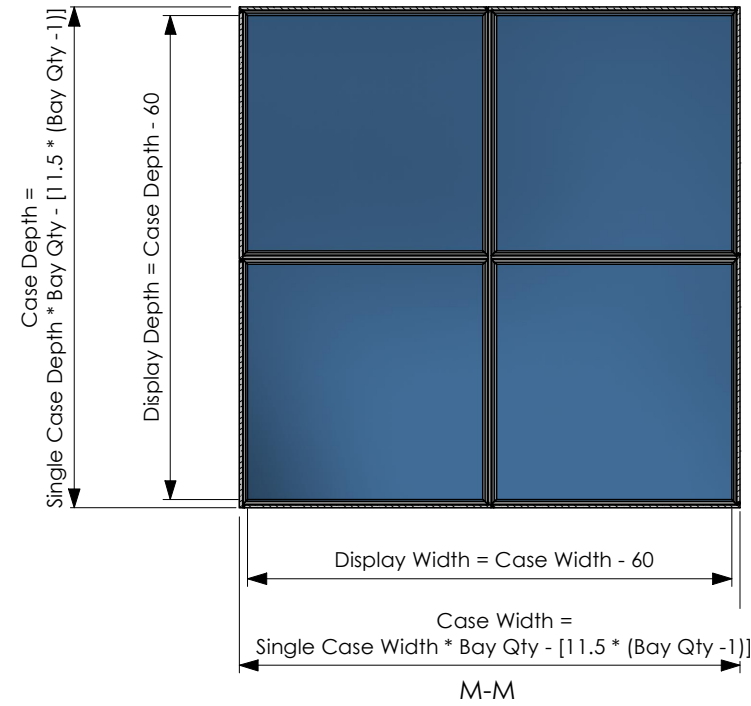

UPPER SINGLE JOINING RAIL

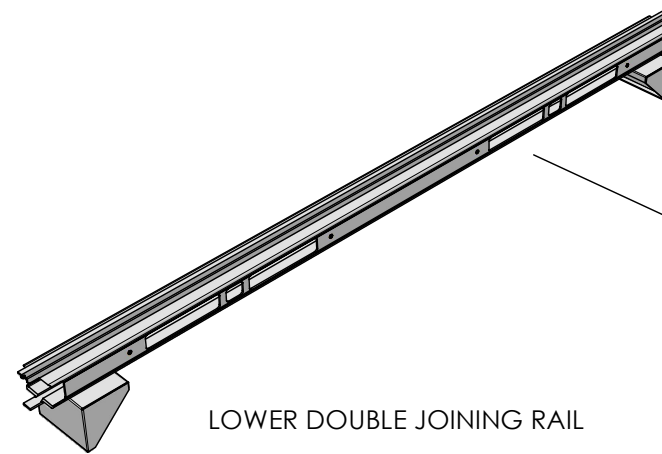

LOWER DOUBLE JOINING RAIL

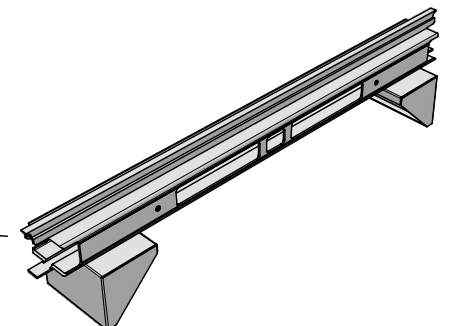
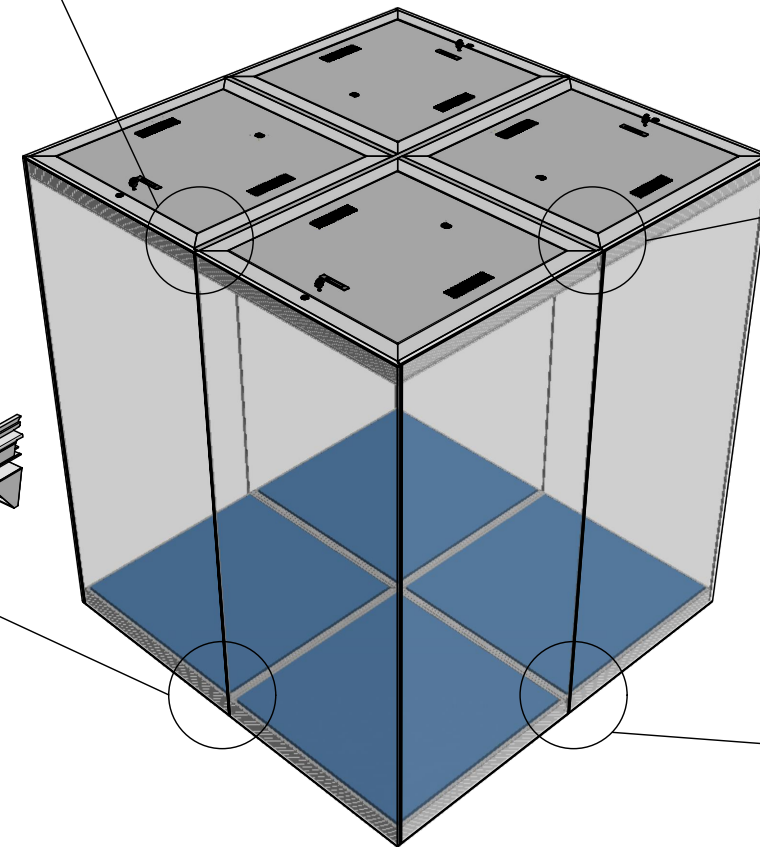

LOWER SINGLE JOINING RAIL

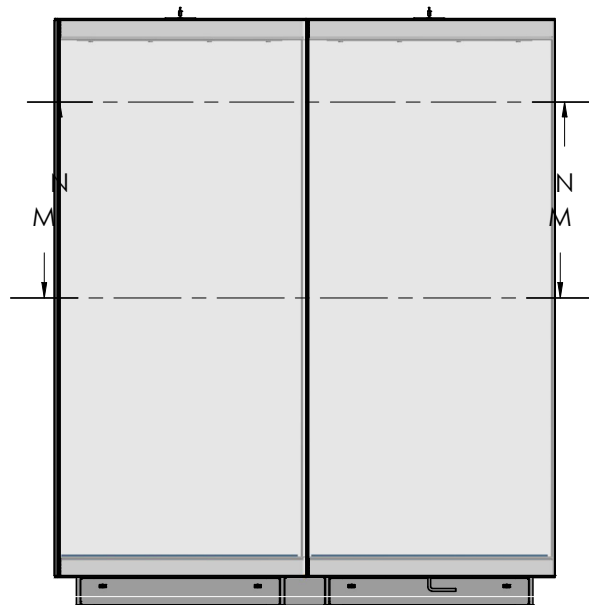

CLICKNETHERFIELD LTD
THE GLASSWORKS, GRANGE ROAD
HOUSTON INDUSTRIAL ESTATE
LIVINGSTON EH54 5DE, SCOTLAND
T +44 (0) 1506 835200
F +44 (0) 1506 835201
E SHOWCASES@CLICKNETHERFIELD.COM
WWW.CLICKNETHERFIELD.COM

REGISTERED IN SCOTLAND NO SC209017 VAT REG 848038508

CM00392-C-02.dwg Rev A